

hanskonner®

инструмент, в который верим [Ханс Кённер]

hanskonner®

инструмент, в который верим [Ханс Кённер]

hanskonner®

инструмент, в который верим [Ханс Кённер]

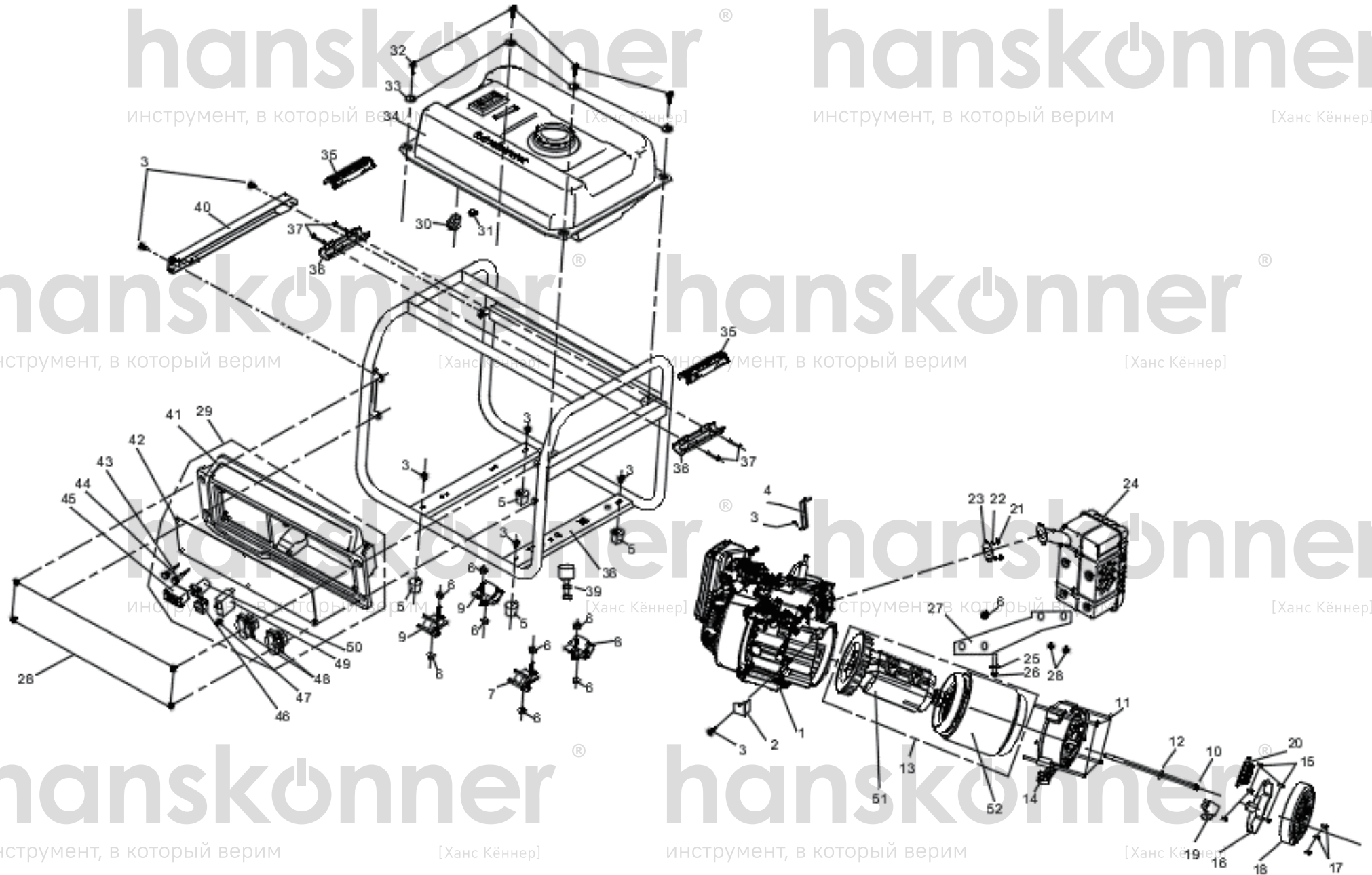

инструмент, в который верим

[Ханс Кённер]

инструмент, в который верим

[Ханс Кённер]

## HPG-3500

NO.	DESCRIPTION	NO.	DESCRIPTION
1	ENGINE ASSEMBLY	27	MUFFLER BRACKET
2	DUSTPROOF PLATE	28	HEXAGONAL FLANGE FACE BOLTS/M6*1/16
3	HEXAGONAL FLANGE FACE BOLTS/M6*1	29	CONTROL PANEL ASSEMBLY
4	AIR FILTER BRACKET	30	FUEL TANK SWITCH
5	RACK VIBRATION DAMPING PADS/WITH NUTS	31	CLAMP
6	HEXAGONAL FLANGE FACE NUT/M8*1.25	32	HEXAGONAL FLANGE FACE BOLT/M6*1/25
7	DAMPING SUPPORT B RIGHT SIDE	33	FUEL TANK GASKET
8	DAMPING SUPPORT A LEFT SIDE	34	FUEL TANK ASSEMBLY
9	DAMPING SUPPORT/CENTERED	35	PROTECTIVE COVER/UPPER
10	HEXAGONAL FLANGE BOLTS/M8*1/220	36	PROTECTIVE COVER/LOWER
11	HEXAGONAL FLANGE BOLTS/M6*1/165	37	CROSS RECESSED PAN HEAD SCREWS
12	FLAT WASHER	38	RACK ASSEMBLY
13	MOTOR ASSEMBLY	39	SINGLE HEAD BOLT VIBRATION DAMPING SEAT/WITH NUTS
14	MOTOR BRACKET	40	RACK BEAM/H4 MODELS
15	HEXAGONAL FLANGE FACE BOLTS/M5*0.8/16	41	CONTROL PANEL COVER
16	VOLTAGE REGULATOR (AVR)	42	CONTROL PANEL
17	HEXAGONAL FLANGE BOLTS/M5*0.8/12	43	POWER INDICATOR
18	MOTOR TAIL COVER	44	OIL WARNING LIGHT
19	CARBON BRUSH	45	THREE-IN-ONE METER/DISPLAY
20	TERMINAL BLOCK	46	FLAMEOUT SWITCH
21	HEXAGONAL NUT/M8*1.25	47	GROUND BOLT M6X20
22	SPRING WASHER	48	AC EUROPEAN SOCKET
23	MUFFLER GASKET	49	CIRCUIT BREAKER
24	MUFFLER PARTS	50	USB/SQUARE/TYPES+A
25	FLAT WASHER	51	ROTOR
26	HEXAGONAL FLANGE FACE BOLTS/M8*1.25/40	52	STATOR

HPG-3500-EX-SCRTT24001

hanskonner® hanskonner®

инструмент, в который верим [Ханс Кённер] инструмент, в который верим [Ханс Кённер]

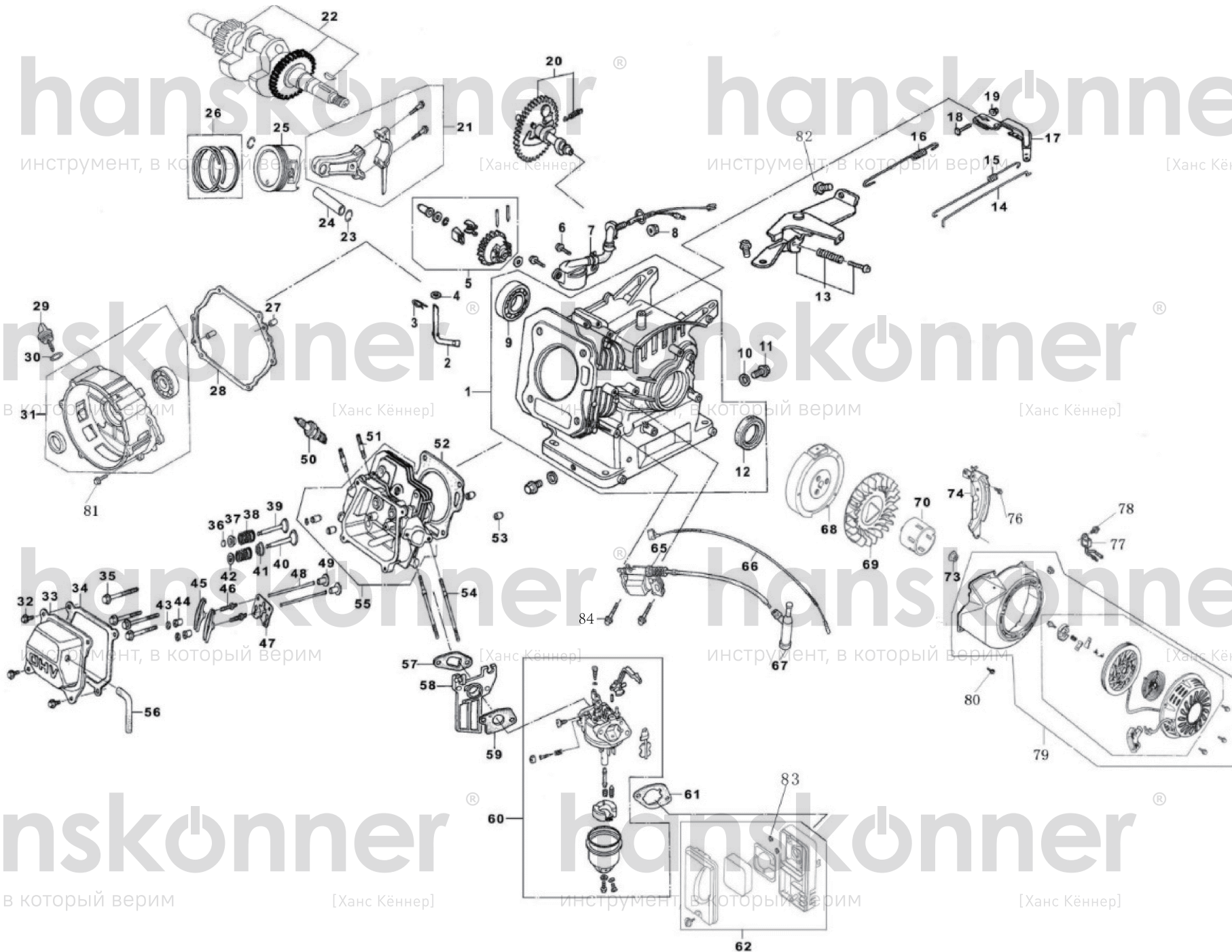

hanskonner® hanskonner®

инструмент, в который верим [Ханс Кённер] инструмент, в который верим [Ханс Кённер]

hanskonner® hanskonner®

инструмент, в который верим [Ханс Кённер] инструмент, в который верим [Ханс Кённер]

hanskonner® hanskonner®

инструмент, в который верим [Ханс Кённер] инструмент, в который верим [Ханс Кённер]

## ENGINE FOR HPG-3500

NO.	DESCRIPTION	NO.	DESCRIPTION	NO.	DESCRIPTION
1	CRANK CASE	28	CRANKSHAFT GASKET	55	CYLINDER HEAD ASSY
2	SHAFT GOVERNOR ARM	29	DIPSTICK	56	WASTE GAS PIPE
3	DOWEL PIN LOCK	30	OIL SEAL,DIPSTICK	57	GASKET,AIR INLET
4	WASHER PLAIN	31	CRANK CASE COVER ASSY	58	CARBURATOR CONNECTING BLOCK
5	GOVERNOR GEAR ASSY	32	FLANGE BOLT	59	CARBURATOR WASHER
6	FLANGE BOLT	33	CYLINDER HEAD COMPONENTS	60	CARBURATOR ASSY
7	OIL SENSOR	34	CYLINDER HEAD GASKET	61	AIR CLEARNER GASKET
8	NUT	35	FLANGE BOLT	62	AIR CLEARNER ASSY
9	BEARING 6205	36	VALVE LOCKING CLIP	65	COIL IGNITION ASSY
10	ALUMINIUM WASHER	37	RETAINER,EXHAUST VALVE SPRING	66	FLAMEOUT SWITCH LINE
11	DRAIN PLUG	38	SPRING VALVE	67	SPARK PLUG CAP
12	OIL SEAL	39	VALVE,EXHAUST	68	FLYWHEEL COMPONENTS
13	GOVERNOR ASSY	40	VALVE,INLET	69	COOLING FAN
14	SPEED CONTROL ROD	41	OIL COVER,INLET	70	STARTING CUP
15	FINE SPRING	42	RETAINER,EXHAUST VALVE SPRING	73	FLANGE NUT
16	SPRING,RETURN	43	NUT,PIVOT ADJUSTING	74	SIDE WIND BOARD
17	ARM,GOVERNOR	44	ROCKER ARM	76	FLANGE BOLT
18	BOLT,GOVERNOR ARM	45	ARM,VALVE ROCKER	77	OIL ALERT
19	NUT	46	BOLT PIVOT	78	FLANGE BOLT
20	CAM SHAFT ASSY	47	PLATE,PUSH ROD GUIDE	79	RECOIL STARTER ASSY
21	CONNECTING ROD	48	ROD,PUSH	80	FLANGE BOLT
22	CRANKSHAFT ASSY WITH WOODRUFF KEY	49	LIFTER VALVE	81	FLANGE BOLT
23	PISTON PIN CLAMP	50	SPARK PLUG	82	FLANGE BOLT
24	PISTON PIN	51	STUD BOLT,EXHAUST	83	FLANGE NUT
25	PISTON	52	CYLINDER HEAD GASKET	84	FLANGE BOLT
26	PISTON RING COMPONENTS	53	DOWEL PIN		
27	DOWEL PIN	54	STUD BOLT,INTAKE		

HPG-3500-EX-SCRTT24001